

# SecureDetect

SecureAccess

SecureBarrier

SecureDetect

SecureLight

SecureView

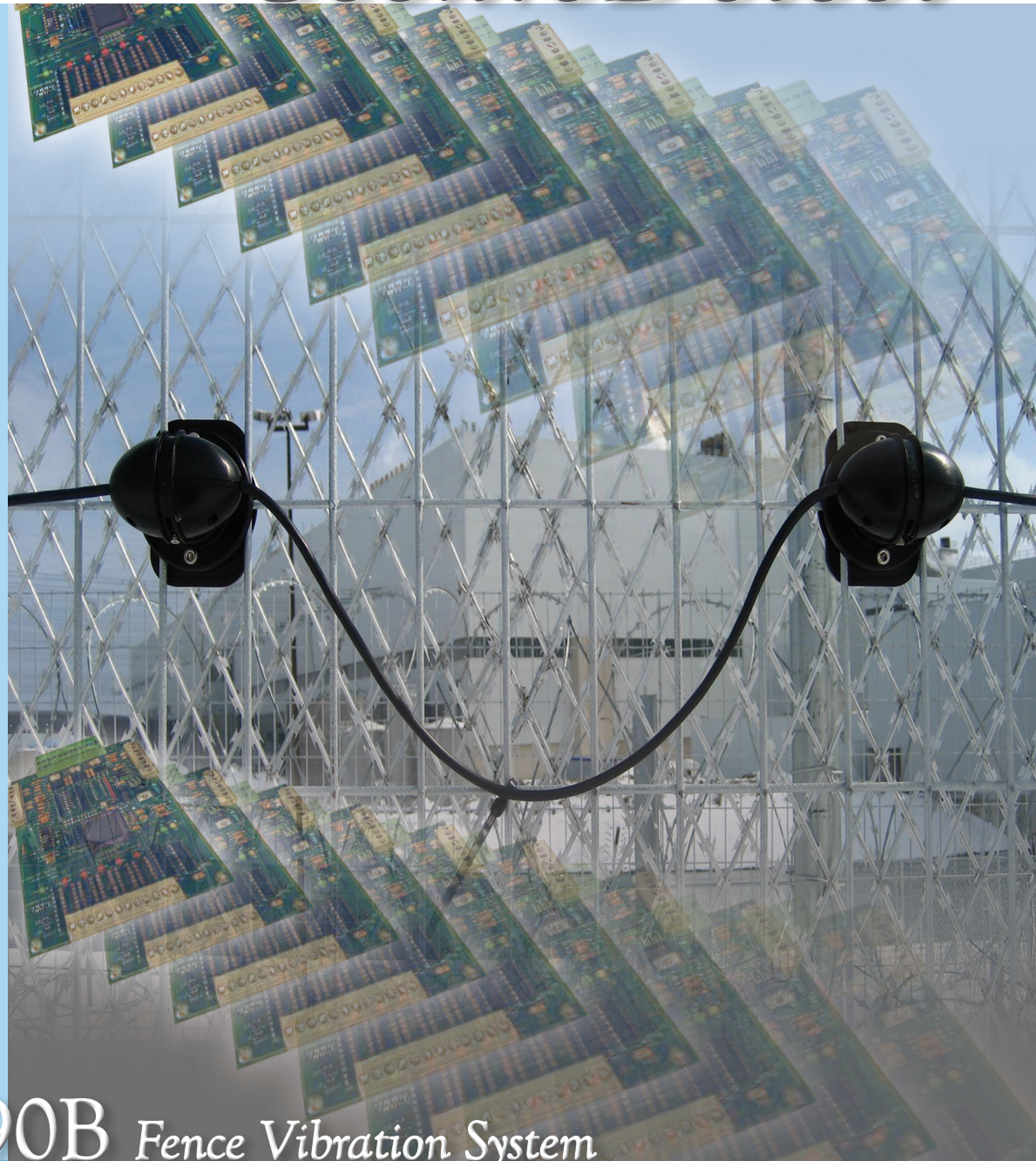

## STI-390B Fence Vibration System

*The STI-390B is a system designed to detect attempted intrusion through a perimeter fence. The vibration sensors fasten to the fence fabric and detect vibrations caused by climbing the fence or by cutting through it.*

*This system is particularly easy to install. It is supplied with the sensors assembled on the cables and ready for mounting. The sensors are usually installed in pairs in a line across the fence. Installation can be in any degree plane with virtually no loss of sensitivity. The sensors can be individually adjusted for sensitivity.*



Contract Holder  
Contract GS-07F-0553U

# SecureDetect

## STI-390B Fence Vibration System

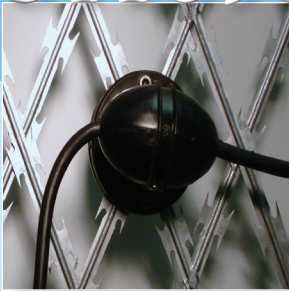

### FEATURES & BENEFITS

Safeguards Technology's STI-390B sensors are made from a special high-resistant long-lasting plastic that requires very little maintenance. The built-in electromechanical filter can distinguish between real and false alarms (average of less than 4 false alarms per month per kilometer [0.62 miles] of fence). The sensors and all electrical connections are hermetically, epoxy sealed assuring absolute protection from dust, corrosion and humidity. The sealing allows the system to be completely operable even under water. The STI-390B meets strict nuclear industry specifications and has played an integral role in providing a high level of security in nuclear facilities throughout the world.

The STI-390B can be linked to a Perimeter Control Center (PCC) that analyzes data from the sensors while filtering out false alarms. With this technology, security personnel are informed of unauthorized intrusion attempts at the precise zone of entry.

### APPLICATION

The STI-390B Fence Vibration System is a very cost-effective electronic intrusion detection system based on technologically enhanced sensors that can be mounted on any type of fence fabric. The STI-390B can transform any fence/wall/gate into an intrusion-proof barrier with only minimum modification.

### SPECIFICATIONS

- Temperature Range: -40°F +140°F
- Relative Humidity: Sensors, cables and junction boxes are completely waterproof, TE-10FZ control unit up to 95%
- Rain, Hail, UV Radiation: Unaffected
- Lightning and Electronic Transients: Meets MIL SPEC A-9094D
- Corrosive Salt Spray: Resistant
- EMI/RFI Processor: Protected against induced voltage and no disturbance induced in regular activation

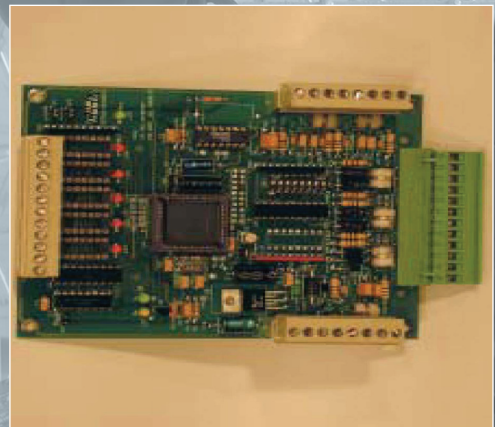
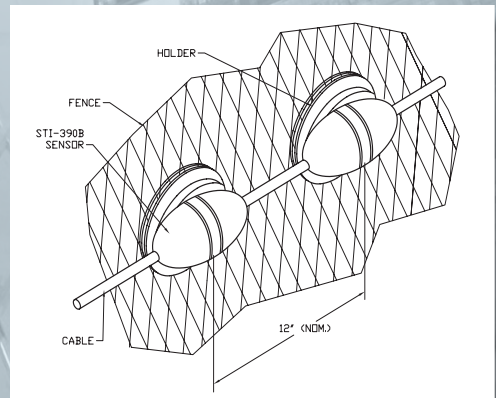

 **SAFEGUARDS  
TECHNOLOGY LLC**  
75 ATLANTIC STREET • HACKENSACK, NJ 07601  
ph 201.488.1022 • fx 201.488.1244  
www.safeguards.com • info@safeguards.com